



LP-HA

Automatic Honeycomb Paper Dispenser User Manual



Hangzhou Bingjia Technology Co., Ltd.

Please contact: info@lockedair.com or call +86 0571 86169196 for service

1. User instructions

Thank you for using the LockedPaper automatic honeycomb dispenser. This manual is written in an easy-to-understand manner, allowing the operator to quickly and easily become familiar with the location of the machine components, the operation of the machine, and the basic principles of troubleshooting and fault correction.

Tip: The operation of different models of machines is slightly different, please pay attention to the tips in the main text of the manual. Only those who have read and understood the chapters such as "Safety", "Product Introduction" and "Product Operation" can operate the machine;

Only service technicians employed by LockedPaper or its dealers are allowed to perform service and repairs on this equipment;

Operator responsibilities include:

- Operate machinery
- Carry out regular maintenance (see Section 5)

NOTE: Only service technicians employed by LockedPaper or a LockedPaper dealer are allowed to service this machine.

2. Safety

2.1. Safety instructions manual

The power supply used by the machine must be consistent with the parameters on the machine nameplate. Misconnection is strictly prohibited. To prevent damage to the machine, please only use the power cord provided with the product.

- Please ensure that the power supply is reliably grounded
- Safety devices must not be turned off or removed
- Warning markings must not be removed or covered (see Machine Warnings)
- Keep work area clean and accessible
- Before moving the machine, unplug the power cord and collect any loose wires together
- Be careful when using tools such as knives or scissors to avoid injuring your hands

Make sure:

- No damage to cables
- Work areas should be well lit
- Work area is well ventilated

Safety specification design: The mechanical structure design complies with CE safety specification requirements. All dangerous parts cannot be touched by hand.

2.2. Machine warning

When the machine is working, it is strictly prohibited to touch any moving parts; Pay attention to the following tips when the machine is working and within 5 minutes after it stops working;



Lightning Tip: Indicates that some machine parts inside the equipment are not electrically insulated. Notice! Risk of electric shock!



Anti-cut hand tip: Indicates that the device has a cutter. Notice! Prevent cuts!



Anti-pinch tip: Indicates that the device has internal transmission components. Notice! Prevent pinching!

Emergency stop switch: If you encounter the following situations, please press the emergency stop switch to cut off the main power supply of the machine:

- Paper pads or other foreign objects are rolled into the machine and the machine cannot operate normally.
- Abnormal sounds are produced inside the machine

- Abnormal heating, machine shell temperature is too high
- Other abnormal situations

2.3. Improper use

The following applications or operations are inappropriate for the machine and are considered improper use:

- Reference to other documents not prepared by LockedPaper
 - Use outdoors or in wet areas
 - Used in areas where explosion accidents may occur
 - Using excess water to wash or clean the machine
- Stand on the machine
- Place objects on or on top of the machine
 - Move the machine while it is running or still connected to AC power

2.4. Storage

- Never place or store the machine in a damp or watery place
- Before using the machine again after long-term storage, it must be inspected by a trained service technician
- The machine should be stored in an environment with a temperature range of -25~+55°C (-13~131°F) and a relative humidity less than 90%RH.



If the machine is brought from a colder area to a warmer area, condensation may form on the machine (inside and outside), which may damage the machine and injure the operator if the power is turned on immediately. Before turning on the power, let the machine return to room temperature and wait for the condensed water to evaporate.

2.5. Transportation

- The machine should not experience severe vibration or impact during transportation;
- The machine must not be exposed to the sun or rain, and should be stored within the required temperature and humidity range.

3. Disclaimer

The manufacturer and its authorized dealers are not responsible for any accident or damage caused by violation of the warnings or instructions contained in the description of this machine or this manual.

- Improper use or maintenance
- Use in other applications or conditions other than those specified in this manual.
- Use of unauthorized parts
- **Use non-LockedPaper material**
- Repairs or modifications without the manufacturer's permission

- Unauthorized modifications to the machine, such as:
 - a. Change the control system
 - b. Welding, mechanical processing, etc.
 - c. Extend the machine or control system

The manufacturer and its authorized dealers are not responsible for:

- Consequential damages caused by machine errors or malfunctions (such as product damage, interruption of company operations, delays, etc.).

4. Operation

4.1. Turn On The Machine

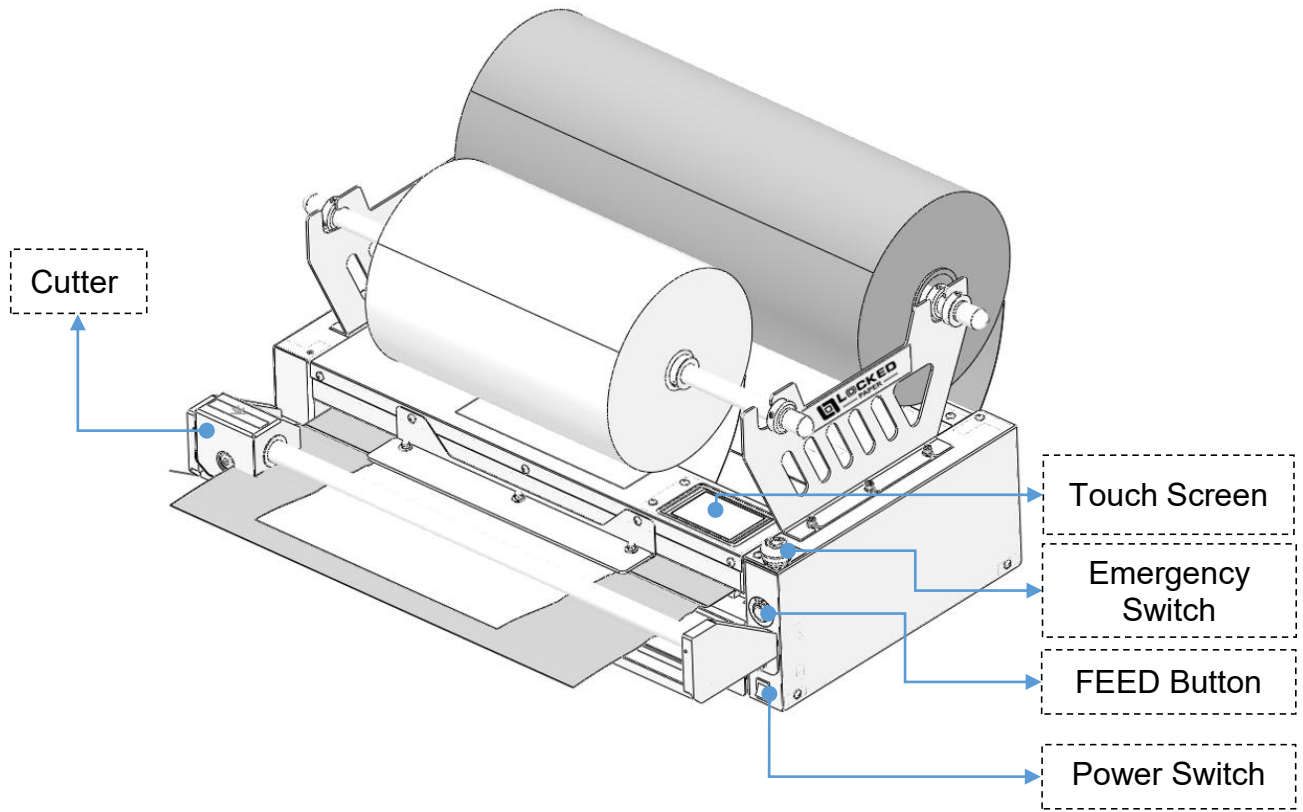

Step1: Blade Module Installation.



×1

Blade Module



×4

M5*16
Combination Screw



×1

4mm Allen Wrench

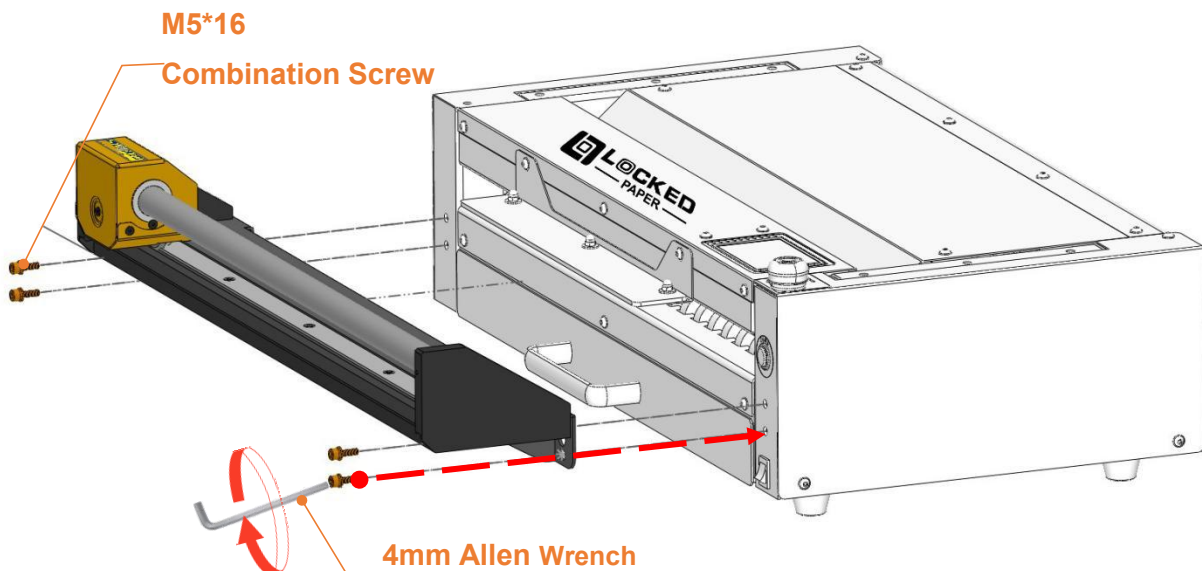

Step2: Left and right Plate Installation.

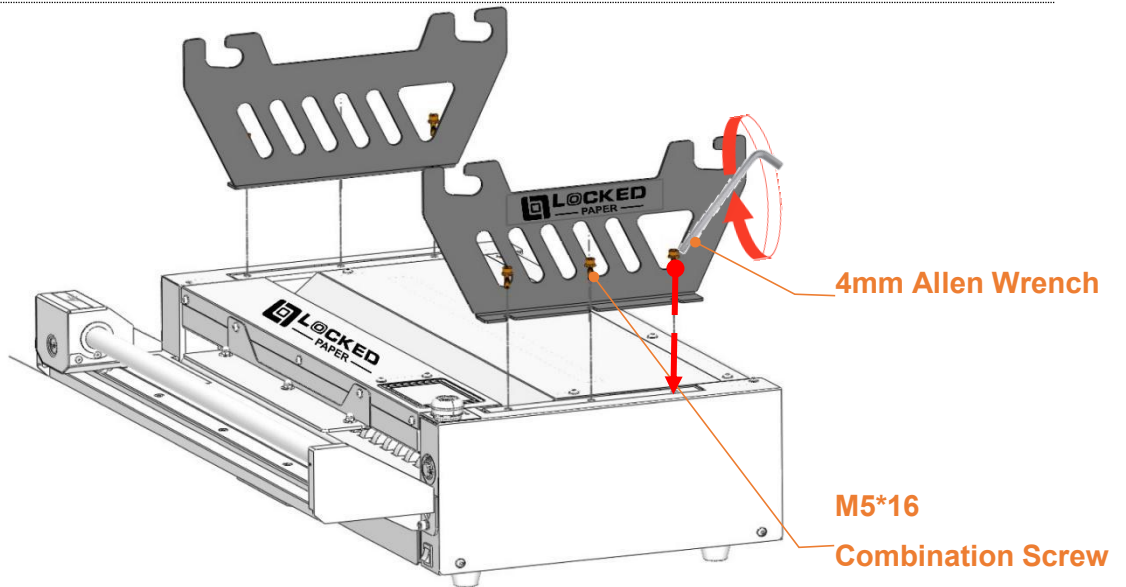
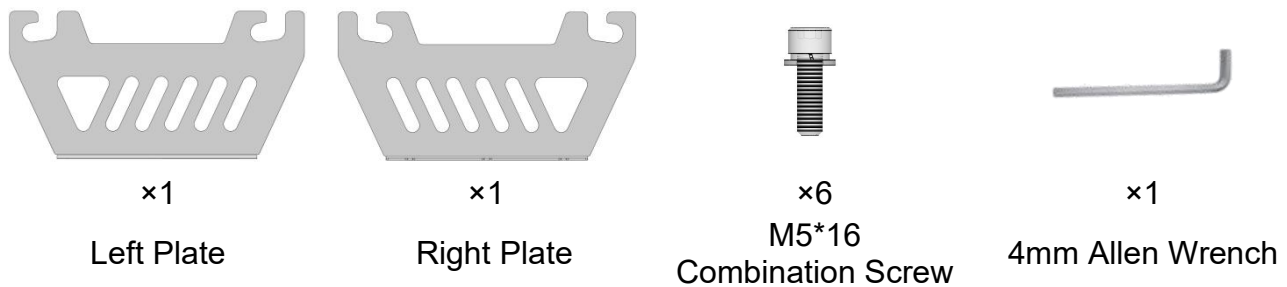

Step3: Support rod 1 and 2 Installation.

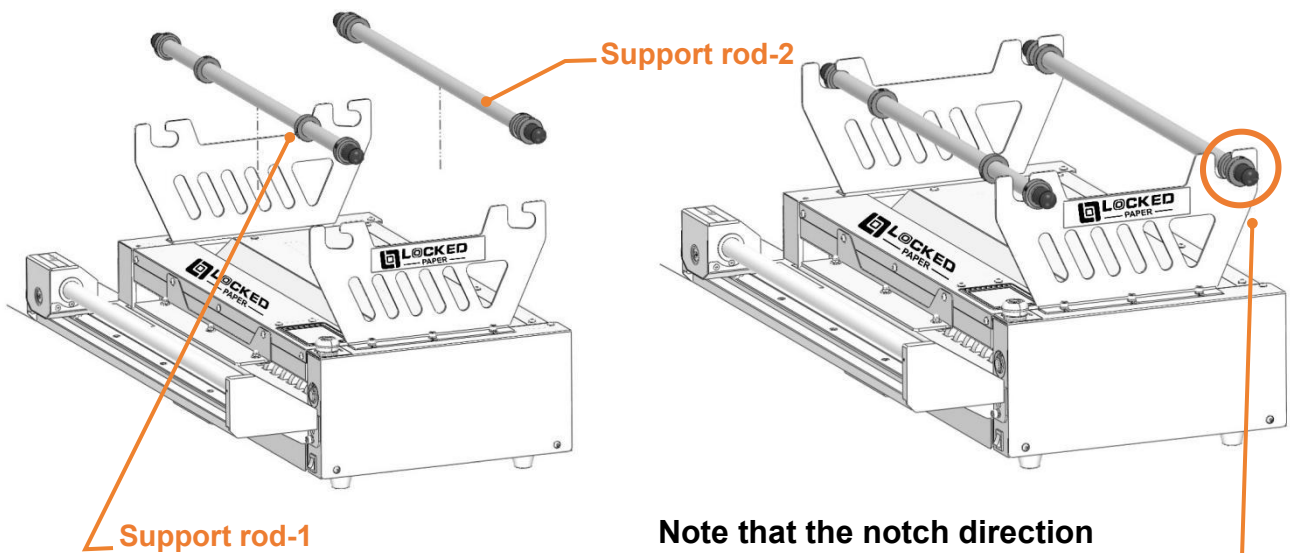

4.2. Turn on the power

Step1:Connect the power plug to a grounded, single-phase, three-wire outlet.

Step2:Plug in the pedal switch.

Step3:Check the status of Emergency Stop switch.

- a. If the switch is pressed, please rotate the switch clockwise to release, then turn on the power to start the machine.
- b. If not, please turn on the power directly to start the machine.

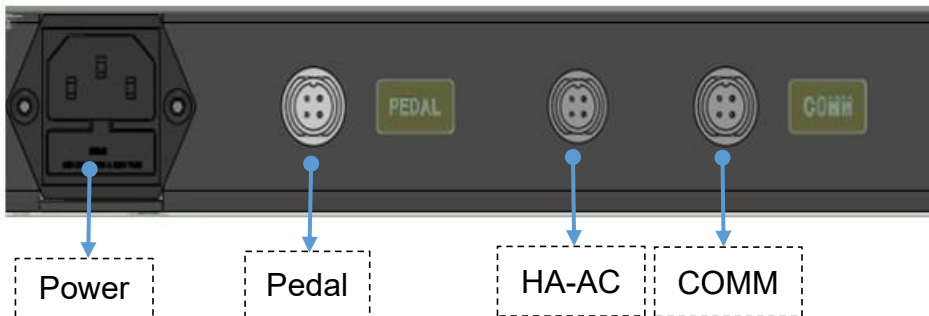

4.3. Feeding

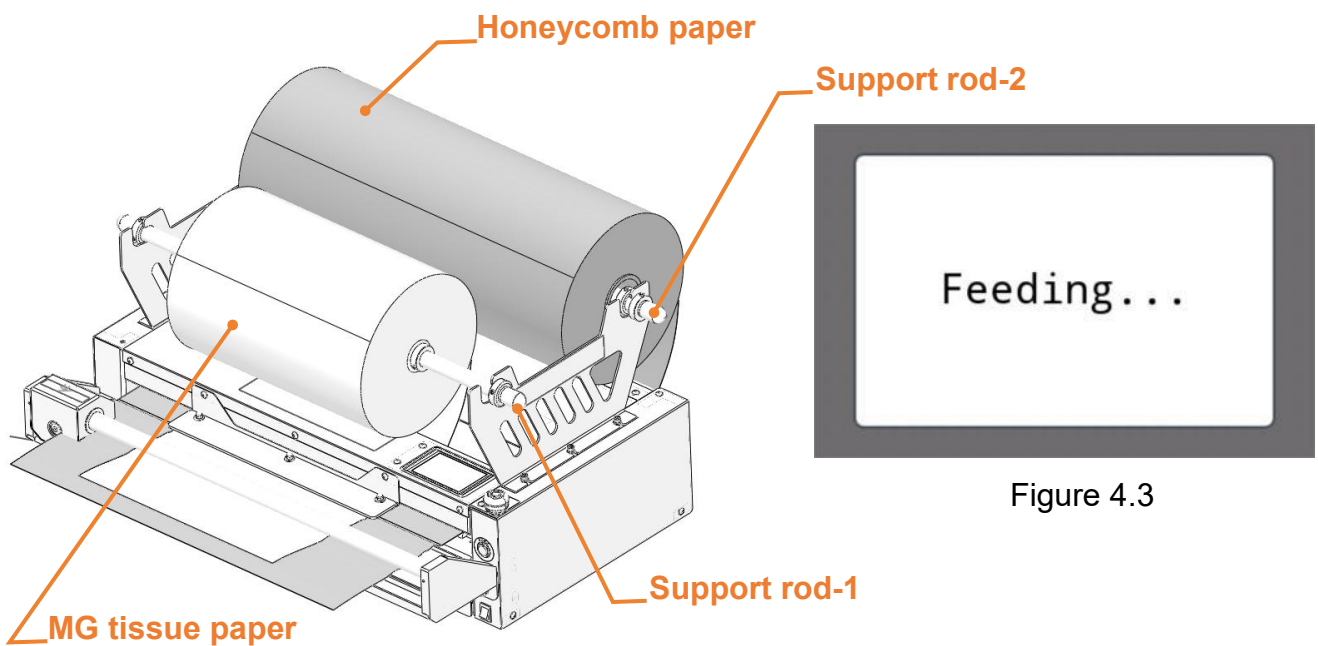
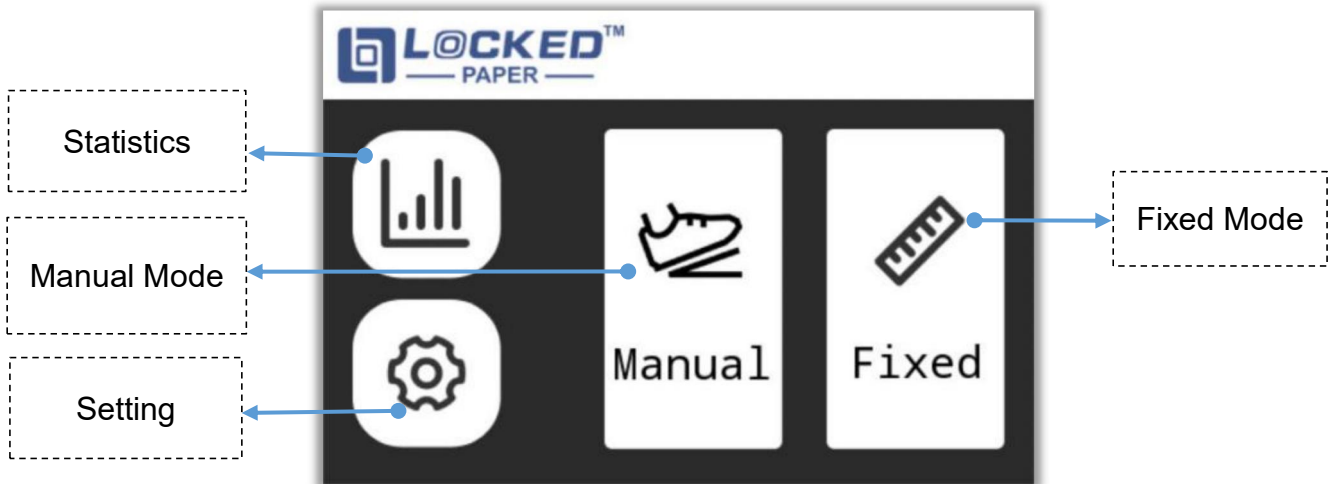

Figure 4.3

1. The MG tissue paper is into the support rod-1, honeycomb paper roll is into the support rod -2;
2. Lead the roll paper into the feeding inlet, long press the **FEED** button and show pop-ups (Figure 4.3). If paper feed out from the outlet, that means it is loaded successfully.

4.4. Home Page

After the boot up is complete, enter the Home Page.



4.4.1. Image Instructions



:Machine working status



:Return to the previous interface



:Machine stop status



:Return to the home page

4.4.2. Parameter Range Description

Length:10~999cm/4~393inch



:Speed adjustment



(The white arrow refers to the speed, 3 kinds of speed is able to be adjusted and the third speed is suggested to be used.)

4.5. Manual Mode

- This mode controls the length of paper output by triggering the switch duration, Loosen stop.



Figure 4.5



- 1) Click  on the Home page to enter, or in the home state and step on the foot pedal, will automatically enter and start running.
- 2) Mode control:
 - Trigger start: click  or step on the pedal to start producing paper bubble.
 - Control length: maintain the trigger state to extend the paper output length.
 - Data record: paper produced length refers to the value of the **Produced Length**.
 - Stop Producing: release  or lift the foot switch to stop paper ejection.

4.6. Fixed Mode

- This mode can produce paper pad with a preset length.



Figure 4.6



- 1) Click  on the Home page to enter.
- 2) Mode control:
 - Preset Diameter: press the input field below **Pad Length** to set the paper pad length.
 - Start Producing: press  or step on the pedal to start producing the paper pad.
 - Stop Producing: when the preset diameter is finished, the machine will stop automatically.Or The machine can be stopped by press  in the process of producing paper pad.

4.7. Statistics Interface

- This interface is used to view the data logging of the machine operation, including total length, total operation time, and total number of paper pads. (The data under this interface cannot be modified.)



Figure 4.7

- 1) Click  on the Home page to enter.
- 2) If you need to use , please contact the after-sales service.

Contact: email: info@lockedair.com or call: +86 0571 86169196

4.8. Setting Interface

- This interface can access to the Diagnosis, Advanced, Language and About interface.



Figure 4.8

- 1) Click  on the Home page to enter.

4.8.1. Diagnosis Interface

• This interface is used to check whether the motor and sensor is normal. Please operate it with the assistance of professional technical personnel.

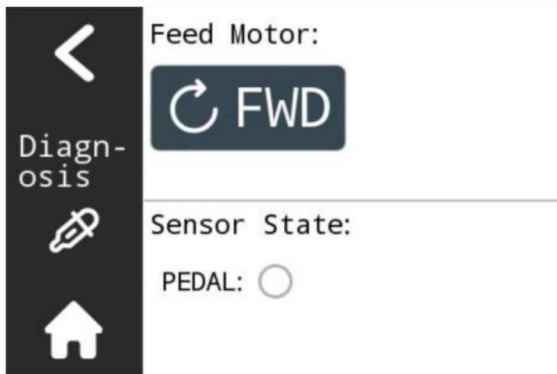





Figure 4.8.1

- 1) Click  on the **Setting** interface to enter.
- 2) Feed Motor: to diagnose whether the motor function is normal.
Hold  the paper feed motor will continue to rotate forward, release to stop.
- 3) Sensor State: to diagnose whether the sensor function is normal.
 PEDAL: It is green when pedal is stepped, and white when released.

4.8.2. Advanced Interface

• This interface is the temporary solution interface in case of any faults. Please operate it with the assistance of professional technical personnel. If you need to use it, please contact the after-sales service.

Contact: email: info@lockedair.com or call: +86 0571 86169196

4.8.3. Language Interface

- This interface is used to switch the language and unit of length .

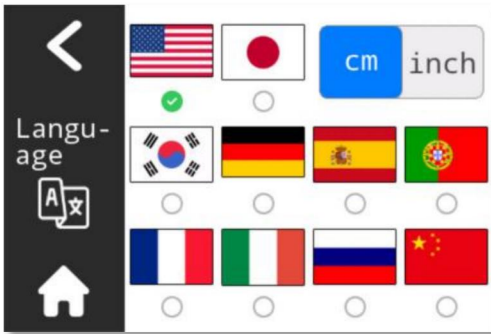

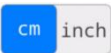

Figure 4.8.3

- 1) Click  on the **Setting** interface to enter.
- 2) Click  switching units.
- 3) Click on the flag to switch the language of the corresponding country, after successful switching, the indicator light below the flag will be lit up.

4.8.4. About Interface

- This interface is used to view machine information and video.



Figure 4.8.4

- 1) Click  on the **Setting** interface to enter.
- 2) Detailed Introduction
 - Contact:LockedPaper Official Website
 - Support:YouTube
 - Info:Version number and equipment information
 - Core: Control board program version
 - HMI: Screen program version

5. Maintenance

5.1. Preventive maintenance

Warning! During all maintenance and repair work on the equipment, the system must be shut down and the power supply disconnected.

- Please be careful of sharp edges and corners of the device to avoid cuts.
- Never operate equipment with safety devices off or removed.

Preventive maintenance time	Maintenance	Content
Every month	Cleaning	<ul style="list-style-type: none"> · Remove dust from drawers · Check and clean whether there is paper entanglement on the rubber roller · Wipe with a dry cloth to remove excess paper dust
	Inspection	<ul style="list-style-type: none"> · Wear and breakage of components · Various adjustment situations · Operation status of various safety facilities · Are warning labels clear and easy to read?
Every year	Professional maintenance	Inspected by qualified personnel at least once a year

5.2. Repair/Replacement Parts

Repair should only be performed by a qualified service technician.

- When replacing parts, only LockedPaper supplied parts can be used.
- Parts can be ordered by LockedPaper's distributors.
- Failure to strictly follow the above instructions may affect the safety of the machine. The manufacturer disclaims no responsibility if the above instructions are not followed.

6. Troubleshooting

6.1. Analysis and treatment of common faults

If the fault occurs is not listed below, please contact the LockedPaper dealer to handle it.

Fault phenomenon	Cause Analysis	Method of exclusion
Can't cut paper	The distance between the fixed knife and the movable knife is too large	Adjust the screw at the bottom of the knife holder to reduce the distance

Step1: Loosen the screws at the bottom of the tool holder.

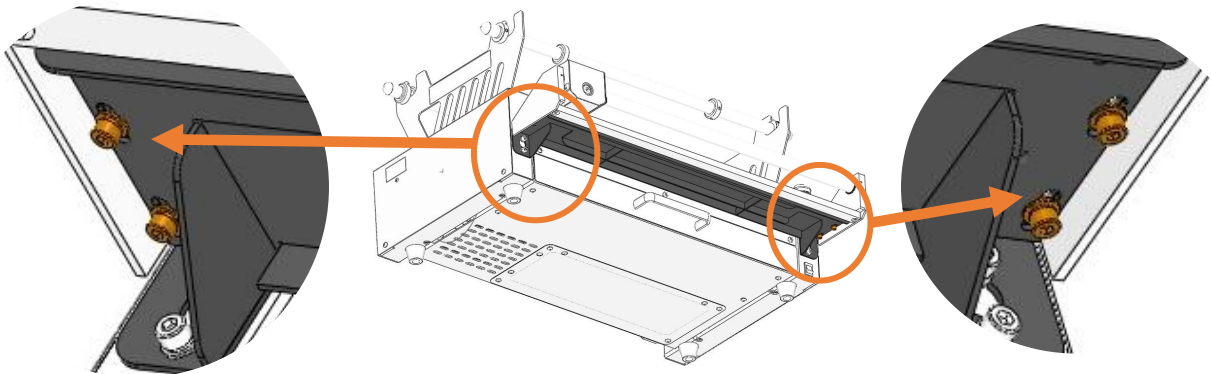

Step2: Move the cutter towards the machine and test the paper cutting effect.

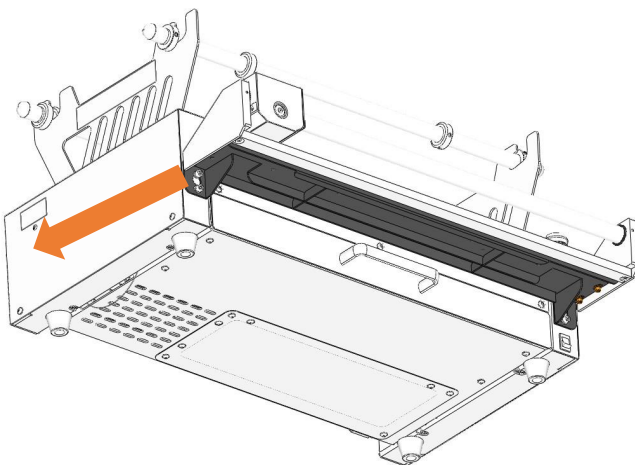

Step3: Tighten the screws of step1.

7. Customer service

7.1. Notice to customers:

LockedPaper™ kraft automatic honeycomb dispenser is manufactured by Hangzhou Bingjia Technology Co., Ltd. and are fully tested before shipment. However, if a problem arises while the machine is operating, please contact our customer service department using any of the service phone numbers listed below.

Customer Service and Spare Parts Service:

1. Please call your LockedPaper customer representative
2. Please contact our customer service by email: info@lockedair.com

7.2. Technical customer service

If any unusual problems occur with the device, please confirm the following information:

1. Customer details: Your company name, contact number
2. The product serial number "BJTLP-HA_____ " can be viewed on the nameplate information on the back of the device.
3. Describe the problems encountered in d.

